



ZIG-ZAG





ZIG-ZAG SYSTEM



PLATFORM
4-11



MANGAGER
12-19



SINGLE & DOUBLE
20-23

SPACE FOR INTERACT

Zig-Zag is a **perfect solution** for companies in which the basic role fulfill teams consisting of a few persons who need space to interact freely. Desk tops enlarged by add-on devices provide more space and allow a few people to join the

team without any problems and continue collective work. **Module character** of the system and reduced pattern-designing are in accordance with the technical and esthetic needs of contemporary office.









The area for **team work** is often connected with the mobility of the workers. In this case the crucial element shall provide **fast and easy access** to sockets for the workers as well as free communication among the members of the team. Upholstered panels hide media-ports offering

place for accessories and trinkets. On the cover of the panels there are openwork containers for documents and additional sources of light. Due to the abovementioned the workstation becomes **more practical**, comfortable and ergonomic.





All elements which constitute the system are a collection of **basic geometric shapes** of a rectangle and a square. Independent and integrated workstations are connected with the simple shape of a desk top, differentiated only by

the width of the working area. The construction of the desk provides **perfect ergonomics** – a wide area for work, a place for a keyboard and documents, a screen, a telephone and all things which are **essential** for a **modern workstation**.





Zig-Zag **platforms** were designed in such a way to provide quick access and do not cause any problems. That is why they can be exchanged and divide the workstands with a straight or

cross-shaped line. The panels are decorated with ornamented openwork covers made of white metal which fastens the partition and provides a **unique character** of the desk.





White metal **openwork** is a characteristic element of the Zig-Zag system. It is designed in a form of zigzags crossing on the frontal parts of the cupboards, embracing the panels

or decorating the additional accessories. Apart from that, the **mobile container** with a system of quietly closing drawers and a pen box allows to keep stationery in order.





Zig-Zag cupboard connects esthetics and **elegance** with **ergonomics**. Impressive frontal parts with a zigzag pattern cover perfectly designed interior with huge drawers and shelves for files. The system provides a possi-

bility to chose the frontal part of the cupboard due to the arrangement – despite the most characteristic openwork the frontal parts made of melamine of **elegant shining** HPL material are also available.





SPACE FOR IMPRESS

Is a simple, **multifunctional** and comfortable system which matches various offices. Starting from the reception desk through the open staff

rooms to the managers' offices – Zig-Zag creates a **modern office** and provides its unique character.





An opportunity to **concentrate** and have a feeling of **discretion** with being open to the contact with the subordinates is the most crucial element in each office. The workstand for a **manager** in the Zig-Zag system perfectly

fulfills these functions and allows to organize work perfectly. Due to handy additional accessories integrated with the desk the most important elements are always accessible.





SPACE TO CREATE

Zig-Zag perfectly functions in a separate area. It is also an optimal place for a small team. **Integrated workstands** lean against the side extensions and allow to organize work in small rooms with a free exchange of ideas to

solve problems. The main part of the extension can be used also as an additional place for documents or office equipment. The desks are equipped with media-ports providing comfort and access to electricity.



19	20	21	22	23	24	25
26	27	28	29	30	01	02
03	04	05	06	07	08	09
10	11	12	13	14	15	16
17	18	19	20	21	22	23
24	25	26	27	28	29	30
31	01	02	03	04	05	06
07	08	09	10	11	12	13

STYCZEN



The partition walls are very useful in a situation when the performed tasks required concentration and silence. Zig-Zag allows to create **independent boxes** consisting of one or a few workstands, separated with additional panels.

The construction of the partition wall allows to assembly various kinds of shelves and additional accessories over the desk. Next to the desk top there is a shuttered cupboard which can be used as a container.



In case of workstations which are located in independent Bowers the most crucial thing is a possibility to use the sockets and the Internet without any problems. Zig-Zag desks are equipped with comfortable and **accessible media-ports** allowing for a quick connection of the office

equipment with the Internet. Esthetic appearance of the workstation is provided by the canals in the partition walls which hide the cables of the electric and communication network. Due to half-open slats additional devices can be connected without any problems and with-

out the need to disassemble the construction. Additional elements such as hanging shelves or shuttered cupboards complete the system in terms of **functionality** and provide a satisfactory amount of space for documents and files.



DESKS

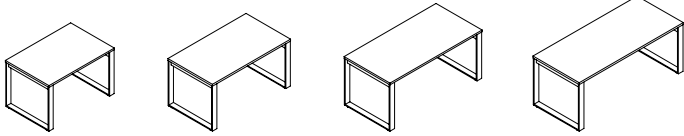

ZBI 02 1200/800/740
ZBI 04 1400/800/740
ZBI 06 1600/800/740
ZBI 08 1800/800/500

DESKS WITH MEDIABOX

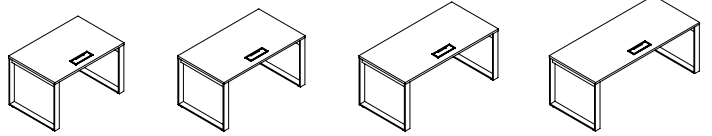

ZBI 02M 1200/800/740
ZBI 04M 1400/800/740
ZBI 06M 1600/800/740
ZBI 08M 1800/800/500

EXTENSION



ZPI 16
1600/600/740

MODESTY PANELS

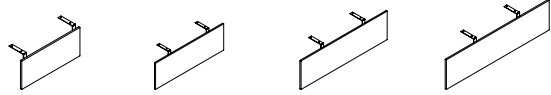

UH 2 1000/18/400
UH 3 1200/18/400
UH 4 1400/18/400
UH 5 1600/18/400

PARTITION WALLS

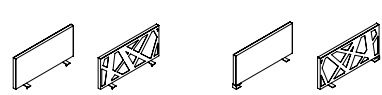

ZP 01 800/18/350
ZP 02 800/18/350

SHELF



ZP 03
400/300/200

SCREENS

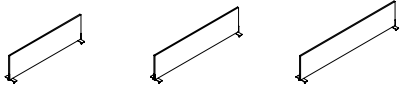

ZP 12 1100/18/350
ZP 14 1300/18/350
ZP 16 1500/18/350

UPHOLSTERED PINBOARDS FOR SCREENS

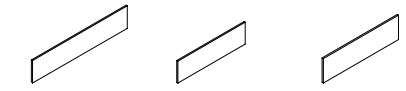

RP 81 1520/14/304
RP 83 1120/14/304
RP 82 1320/14/304

COFFEE TABLE

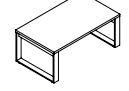

ZBS 10
1200/700/550

MOBILE PEDESTAL



SLK 13
470/616/580

CABINETS

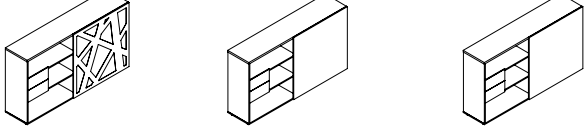

ZS 01 2000/434/1129
ZS 02 2000/434/1129
HPL front
ZS 03 2000/434/1129
melamine front

MANAGERIAL DESK

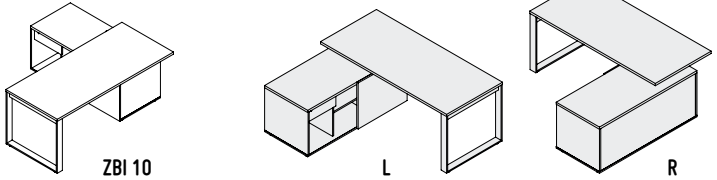

ZBI 10
1800/800/500

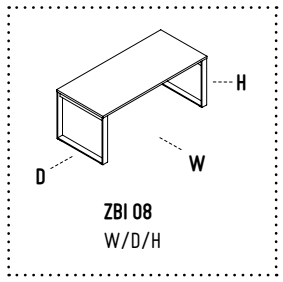

melamine boards:

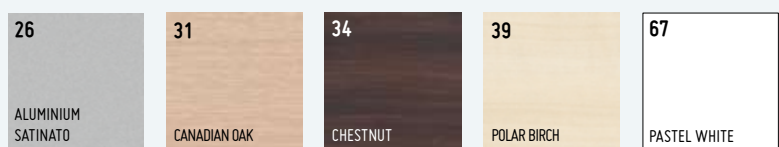

HPL:

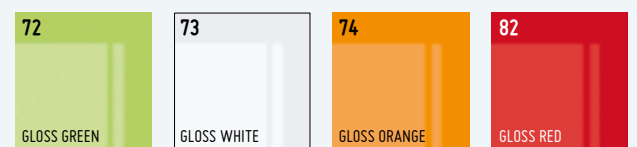

BENCHES

example set:

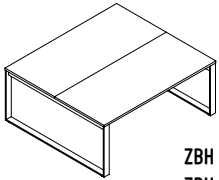

ZBH 02 1200/1600/740
ZBH 04 1400/1600/740
ZBH 06 1600/1600/740
ZBH 08 1800/1600/740

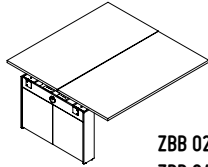

ZBB 02 1200/1600/740
ZBB 04 1400/1600/740
ZBB 06 1600/1600/740
ZBB 08 1800/1600/740

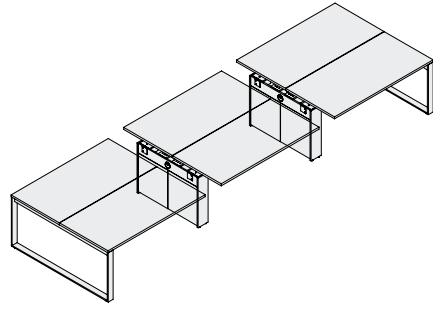

BENCHES WITH MEDIABOX

example set:

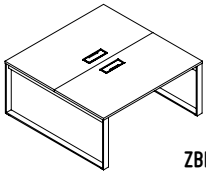

ZBH 02M 1200/1600/740
ZBH 04M 1400/1600/740
ZBH 06M 1600/1600/740
ZBH 08M 1800/1600/740

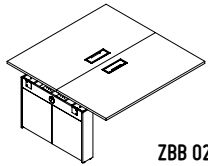

ZBB 02M 1200/1600/740
ZBB 04M 1400/1600/740
ZBB 06M 1600/1600/740
ZBB 08M 1800/1600/740

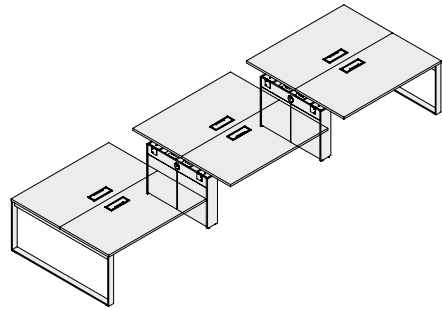

PLATFORM

example set:

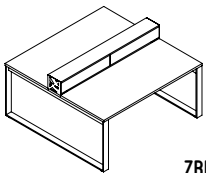

ZBH 14 1400/1600/740
ZBH 16 1600/1600/740

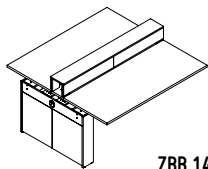

ZBB 14 1400/1600/740
ZBB 16 1600/1600/740

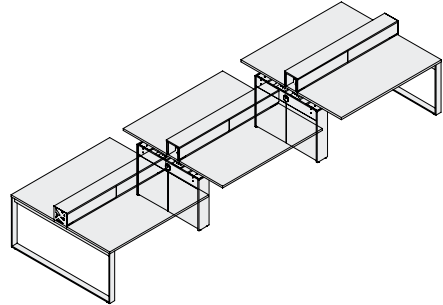

The partner (co-organiser) is IKER a producer of modern upholstery furniture, chairs and lighting. The followings pieces of furniture were used: Lemming, Plumm and Magnetic. We welcome everyone to see the full range of our collection at www.iker.com.pl



support frames:

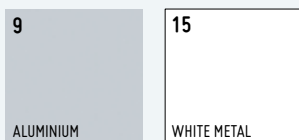

fabrics:

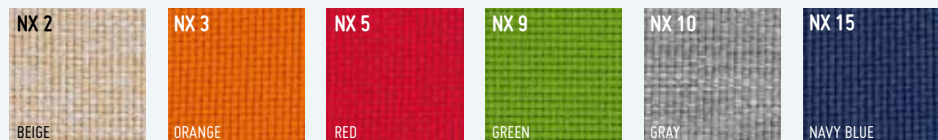

This catalogue is intended as information only, does not stand for trade offer.



www.mdd.eu info@mdd.eu